

WORKTOP FREEZER (0°F)

Model: SWF48NBS

Natural Refrigerant R-290 Model

48" Worktop Freezer with Solid Doors and 5½" Backsplash

Stainless steel front, top and end panels, aluminum back and interior.



Options and Accessories

(upcharge and lead times may apply)

Stainless steel interior	Stainless steel shelves
Stainless steel back	Door locks
Drawers in lieu of doors (consult factory)**	Special electrical requirements (consult factory)
Additional epoxy coated steel shelves	Expansion valve system
Overshelves (single or double)	Adjustable Legs

Consult factory for other model configurations, options and accessories.

**Two tier: (1) 12 x 18 x 6 pan per drawer or (1) 1/2 size x 6 & (1) 1/3 x 6 pans per drawer

Continental
Refrigerator

Toll-Free: 800-523-7138
Phone: 215-244-1400
Fax: 215-244-9579

539 Dunksferry Road
Bensalem, PA 19020
www.continentalrefrigerator.com

Project Name:

Model Specified:

Location:

Item No:

Quantity:

AIA #:

SIS #:

Standard Model Features

REFRIGERATION SYSTEM

Performance rated refrigeration system

Natural, environmentally safe, high efficiency R-290 refrigerant¹

Automatic, hot gas condensate evaporator

Non-corrosive, plasticized fin evaporator coil

Easily serviceable, back mounted compressor

CABINET ARCHITECTURE

2" non-CFC polyurethane foam insulation

Smooth, polished chrome door handles

Spring loaded, self closing doors

Magnetic snap in Santoprene™ door gaskets

Heavy duty, epoxy coated steel shelves

Completely enclosed, vented and removable case back

5" casters

MODEL FEATURES

Field rehingeable doors

Electronic controller with digital display & hi/low alarm

Automatic electric defrost

¹ R-290 refrigerant meets all federal and state regulatory requirements.

APPROVAL:

Model Specifications

DIMENSIONAL DATA

Net Capacity (cubic feet)	13.4 (379 cu l)
Width, Overall (inches)	48 (1219 mm)
Depth, Overall (inches) (including handles & bumpers)	32 ³ / ₁₆ (818 mm)
Height, Overall (inches) (including 5" casters)	40 ³ / ₄ (1035 mm)
Shelf Area (square feet)	6.8 (0.6 sq m)
Number of Shelves	2
Number of Doors	2
Interior Depth (inches)	See Drawing
Interior Height (inches)	26 ¹ / ₄ (667 mm)
Interior Width (inches)	44 (1118 mm)

REFRIGERANT DATA

Condensing Unit Size (H.P.)	¹ / ₂
Capacity (BTU per hour)*	2078

ELECTRICAL DATA

Voltage (International)	115/60/1 (220/50/1)
Total Amps (International)	7.7 (4.3)
Defrost Amps (International)	4.4 (2.5)
10 ft. Cord/Plug [attached] (International)	Yes (No)

SHIPPING DATA

Weight (pounds)	258 (117 kg)
Height - Crated (inches)	48 ³ / ₄ (1238 mm)
Width - Crated (inches)	56 (1422 mm)
Depth - Crated (inches)	37 ¹ / ₄ (946 mm)

* Rating @ -15°F evaporator, 90°F ambient
 Figures in parentheses reflect metric equivalents rounded to the nearest whole unit.



Equipped with one NEMA-5-15P Plug
 (varies by country)

Model Plan Views

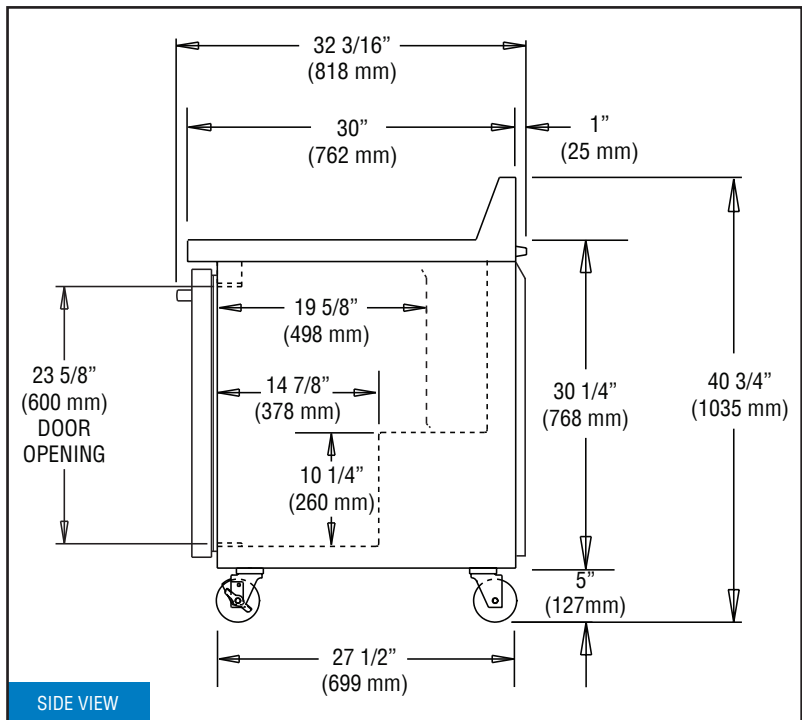
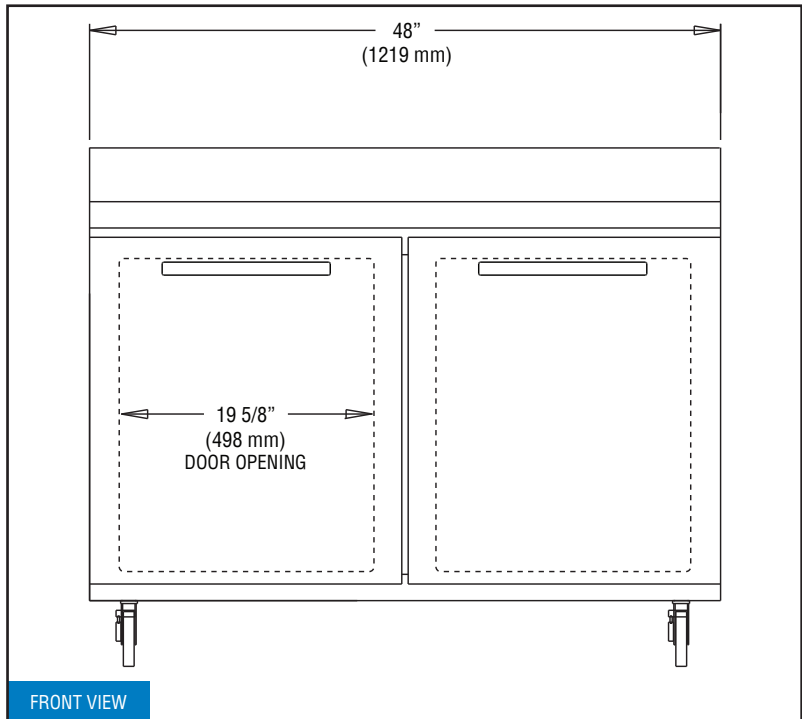

IMPORTANT NOTE: If the cabinet is located directly against a wall, a minimum clearance of 3" is required on sides, front and rear.

Continental
 Refrigerator

Toll-Free: 800-523-7138
 Phone: 215-244-1400
 Fax: 215-244-9579

539 Dunksferry Road
 Bensalem, PA 19020
www.continentalrefrigerator.com

Due to our continued efforts in developing innovative products, specifications subject to change without notice.

